

Nick Netzer

Evolution of Time Preferences and Attitudes Towards Risk

Research Paper Series
Thurgau Institute of Economics and Department of Economics
at the University of Konstanz



EVOLUTION OF TIME PREFERENCES AND ATTITUDES TOWARDS RISK

Nick Netzer^{*†}

This Version
March 2008

Abstract

This paper explores a general model of the evolution and adaption of hedonic utility. It is shown that optimal utility will be increasing strongly in regions where choices have to be made often and decision mistakes have a severe impact on fitness. Several applications are suggested. In the context of intertemporal preferences, the model offers an evolutionary explanation for the existence of conflicting short- and long-run interests that lead to dynamic inconsistency. Concerning attitudes towards risk, an evolutionary explanation is given for S-shaped value functions that adjust to the decision-maker's environment.

JEL-classification: D01, D81, D87, D90.

Keywords: Evolution of Utility, Risk Attitudes, Time Preferences.

*University of Konstanz, Department of Economics, Box D150, 78457 Konstanz, Germany. Email: nick.netzer@uni-konstanz.de.

†The author would like to thank Carlos Alós-Ferrer, Urs Fischbacher, Normann Lorenz, Gordon Myers, Tim Netzer, Arthur Robson, Florian Scheuer, Harris Schlesinger, and seminar participants at Simon Fraser University and the University of Konstanz for very valuable comments. Part of this research was undertaken during a visit to Simon Fraser University. Financial support by the German Academic Exchange Service (DAAD) is gratefully acknowledged. All errors are my own.

1 Introduction

This paper is based on the hypothesis that individual decisions are guided by hedonic utility. An individual who faces several alternatives will choose the one that promises the greatest pleasure, or happiness. Then, given that the properties of a hedonic utility function determine individual behavior, and individual behavior determines biological fitness, evolutionary forces will have shaped our utility during the long time in which the modern human being evolved.

In this sense, hedonic utility can be considered as a reward system that induces individuals to make optimal choices, a view which is supported both by theory and evidence from neuroscience.¹ As Kupfermann, Kandel, and Iversen (2000, p. 1007) express it: “Pleasure is unquestionably a key factor in controlling the motivated behaviors of humans”. For the economist, the interesting question is then about the properties of the evolutionary optimal reward system, and how these properties adapt to the environment in which individuals make choices.

The present paper reconsiders and solves a general model of the evolution of utility suggested by Robson (2001a), which predicts how cardinal properties of utility functions should adapt to the decision environment. It turns out that the optimal utility function will be steep in regions where decisions have to be made frequently, and where wrong decisions would lead to large losses in fitness. In those regions, even small changes in consumption will cause large changes in happiness. The evolution of context specific utility functions is then shown to be optimal whenever the decisions which our ancestors had to take arrived in distinct choice situations. The model can also be extended to incorporate learning about evolutionary relevant attributes of available options.

The general model suggests several applications. Concerning intertemporal decisions, evolution may have endowed us with different utility functions for short-run and for long-run decisions. The model therefore provides an evo-

¹The somatic marker hypothesis by Damasio (1994) states that decision alternatives are evaluated according to emotions attributed to them. Bechara, Damasio, and Damasio (2000) survey several studies that support this claim. In an experiment with monkeys, Padoa-Schioppa and Assad (2006) identify neurons in the orbitofrontal cortex whose state represents the value of alternatives in choice situations. The orbitofrontal cortex is generally considered to be responsible “for linking food and other types of reward to hedonic experience” (Kringelbach 2005).

lutionary justification for the “multiple-selves” approach to time discounting (see Frederick, Loewenstein, and O’Donoghue (2002) for an overview), where dynamic inconsistency arises from a conflict between different decision mechanisms. This view has been corroborated by the results of McClure, Laibson, Loewenstein, and Cohen (2004), who show that different parts of the human brain are active in short-run and in long-run decisions. The present model predicts that conflict between the “myopic” and the “farsighted” mechanism is more likely to occur if the decision-maker is adapted to small payoffs in the short-run. It also sheds light on the evolutionary role of precommitment as introduced by Strotz (1955).

In the context of attitudes towards risk, the model highlights an influence of environmental randomness which has not yet been discussed by the literature. Risk attitudes will not only be influenced by the technology that converts consumption into fitness, as in Robson (1996) and (2001b), but also by the distribution according to which opportunities arise for the decision maker.² The model then offers an immediate evolutionary rationale for S-shaped value functions as in prospect theory (Kahneman and Tversky 1979). Most interestingly, it identifies the individual’s reference point with the peak of the density that describes the availability of alternatives. This provides a clear prediction of the reference point even in highly stochastic environments.

The contributions by Rayo and Becker (2007a) and (2007b) also deal with the evolution and adaption of hedonic utility. In their model, optimal happiness derived from income is a step function with a unique jump, which can be interpreted as the aspiration level an agent wants to achieve. The aspiration level can then be shown to adjust over time and in accordance with income levels of a peer group, given that payoffs are correlated over time and across individuals. This offers an evolutionary explanation for habit formation and peer comparisons, phenomena frequently observed in happiness surveys.³ The present paper addresses different questions, making use of a different model. While the underlying adaption mechanisms share similarities – in the sense that utility adjusts to the decision environment like an

²The literature, including Cooper and Kaplan (1982), Robson (1996), Bergstrom (1997) and Curry (2001) has also highlighted the role of aggregate risk, which makes deviations from standard expected utility maximization evolutionarily optimal.

³Samuelson (2004) shows that relative consumption effects can be an evolutionary optimal way for the decision-maker to utilize information about the state of nature contained in the consumption of others.

eye to the ambient brightness (Frederick and Loewenstein 1999) – the model outlined below derives utility as a tool to make reasonable comparisons between any pair of alternatives, as opposed to identifying only the best out of a large set. For the purpose of the paper, this turns out to be the appropriate starting point.

The paper is organized as follows. The general model and its solution are presented in section 2. Section 3 is devoted to the evolution of intertemporal preferences. Section 4 is concerned with attitudes towards risk. Section 5 concludes. More formal material can be found in the Appendix.

2 A General Model

2.1 Description

The model in this section has been suggested by Robson (2001a). It has been solved there for an approximate evolutionary criterion, the *probability of mistakes* criterion. In the following, it will be solved under the correct objective, the *expected loss* criterion.

Assume an agent repeatedly has to make choices between alternatives from a set $X = [a, b]$, which are identified with fitness. Thus, alternative $x \in X$ yields fitness x , where fitness could simply be thought of as the number of offspring.⁴ When making a decision, the agent does not face the whole set X , but only two alternatives that are independently drawn from X according to the same random distribution. The agent has to choose one of these alternatives. It will be assumed throughout that the random distribution can be represented by a bounded density f with finitely many discontinuities. The corresponding distribution function is denoted by F .

The distribution F represents the agent's environment by describing the availability of different alternatives. For example, during good times, in fertile geographical regions, or under a favorable climate, large fitness alternatives will be available with greater probability than otherwise. Changes in the environment can later be modeled through changing distributions. For the moment, the distribution is considered as fixed.

The agent is endowed with a hedonic utility function that assigns a level

⁴The case where alternatives are not directly equated with fitness levels is considered later in this section.

of pleasure or happiness to each element in X . The alternative that promises larger pleasure will be chosen. The question now is: which utility function leads to the largest expected fitness? It is motivated by the idea that evolution will eventually have “discovered” and selected this optimal function.

Without any restrictions on the set of admissible functions, the problem is trivial. Any strictly increasing utility function ensures that the better of any two alternatives will correctly be identified. This is, on the other hand, not a realistic assumption. Happiness cannot be perceived in arbitrarily fine shades, due to limitations of human sensory abilities.⁵ This constraint can be modeled by assuming that utility can only take discrete, albeit extremely many values. In the following, the set of admissible utility functions is thus restricted to the set of increasing step functions with $N \in \mathbb{N}$ jumps, each corresponding to a utility increment of size $1/N$. As a result, the agent cannot distinguish two alternatives located on the same step of the utility function. Any choice between such alternatives will have to be random and a mistake can occur. Clearly, different step utility functions will then lead to different levels of expected fitness.

The size of N measures the degree of the perceptual constraint, which vanishes as $N \rightarrow \infty$,⁶ while the assumption of utility increments of size $1/N$ ensures that utility is normalized to the interval $[0, 1]$ for all values of N . In the following, results will be derived for the limiting case where $N \rightarrow \infty$, motivated by the presumption that perceptual constraints do exist but are small. Also, the optimal limiting utility function turns out to be continuous. It is thus an easy-to-deal-with approximation for a step function with a huge number of steps.

The problem of finding the optimal step utility function is equivalent to the problem of locating N thresholds in the set X , where two alternatives can only be distinguished if there is at least one threshold between them.⁷ Whenever two alternatives are drawn from in between two neighboring thresholds, the agent will choose the worse one with probability $1/2$. Robson (2001a) has analyzed the problem of locating the thresholds to minimize the probability of such mistakes, obtaining a simple and intuitive solution, which will be replicated below. The appropriate evolutionary criterion, however, is the

⁵See, for example, Gardner and Martin (2000).

⁶The assumption of a large but finite N is analogous to the limited perception constraint by Rayo and Becker (2007a).

⁷This representation of the problem is in fact the one used by Robson (2001a).

maximization of expected fitness, or, equivalently, the minimization of the expected loss due to wrong decisions.

2.2 Solution

The problem is solved here in three stages. First, the density f is approximated by a sequence of step densities with finitely many steps, $(\hat{f}_S)_{S \in \mathbb{N}}$, in a way that ensures uniform convergence to f as the number of steps grows to infinity, i.e. as $S \rightarrow \infty$. The technical details of the approximation are given in the Appendix, Section 6.1. Second, the problem of optimal threshold location is solved for these step densities, yielding utility functions for the limit as $N \rightarrow \infty$.⁸ Finally, the behavior of these functions is examined as the step densities converge to f .

To obtain the utility of an alternative $x \in X$ for a fixed profile of N thresholds, the number of thresholds below x has to be multiplied by $1/N$. Denote then by $\theta_{N,S}(x)$ the number of thresholds below x given that N thresholds have been located to maximize expected fitness under the step density \hat{f}_S . The resulting utility is given by $U_{N,S}(x) = \theta_{N,S}(x)/N$. For comparison, let $\vartheta_{N,S}(x)$ be the number of thresholds below x if the probability of mistakes is minimized, yielding utility $V_{N,S}(x) = \vartheta_{N,S}(x)/N$. The main result of this section, proven in the Appendix, Section 6.2, can now be stated as follows:

Theorem 2.1. *For each $x \in X$*

$$V(x) := \lim_{S \rightarrow \infty} \lim_{N \rightarrow \infty} V_{N,S}(x) = \int_a^x f(y) dy = F(x),$$

and

$$U(x) := \lim_{S \rightarrow \infty} \lim_{N \rightarrow \infty} U_{N,S}(x) = c \int_a^x f(y)^{2/3} dy,$$

where $c = (\int_a^b f(y)^{2/3} dy)^{-1}$ is a normalizing constant.

The limiting utility function $V(x)$, which follows from minimizing the probability of mistakes, equals the distribution function $F(x)$. The same

⁸It is easy to show that an optimal solution to the problem exists for any number of thresholds N . Let $T = \{t \in [a, b]^N | a \leq t_1 \leq \dots \leq t_N \leq b\}$ be the domain of the optimization, where t_k denotes the position of the k -th smallest threshold in $[a, b]$. Clearly, T is compact. Since the loss function as defined in the Appendix is continuous, the statement follows from the Weierstrass Theorem. Should there be several solutions, the following results hold for any selection of them.

result has been obtained by Robson (2001a), who solves for the optimal threshold positions directly.⁹ Intuitively, when only the mistake probability is concerned, many thresholds should be allocated to regions of X where decisions have to be made with large probability, i.e. where the density $f(x)$ is large. Avoiding mistakes in this region is particularly beneficial. The limiting utility function will then be steep in this region, resembling the distribution function.

Evolution maximizes expected fitness, for which the size of mistakes matters as well. As the distance between two neighboring thresholds varies, both the mistake probability and the average size of a mistake between these two thresholds are affected in the same direction. The overall expected fitness loss between two thresholds then depends on the cube of the distance between them, making strong variations in the distances between thresholds undesirable. The evolutionary optimal distribution of thresholds is thus more even than indicated by the first result. In particular, this implies that the slope of $U(x)$ will not vary as much as the slope of $F(x)$, which is achieved by the concave transformation of $f(x)$ in the definition of $U(x)$.¹⁰

Besides Theorem 2.1, the threshold model delivers an intuitive interpretation for the slope of a utility function. Since a large slope derives from a dense allocation of thresholds, one can think of marginal utility as the degree of attention devoted to the respective alternative. Marginal utility will be large in areas where correct decisions are especially important. The curvature properties of a utility function then correspond to changes in attention.

2.3 Extensions

The analysis above proceeded under the assumption that choices are made between fitness levels. In reality, however, choice is between consumption bundles, and we do unquestionably derive utility directly from consumption of various goods, rather than from their fitness value.¹¹

To capture this, assume that the individual makes pairwise choices between alternatives from a set $Y \subseteq \mathbb{R}$, which are independently drawn according to a distribution function G . The alternatives are then mapped to

⁹When the mistakes probability is minimized, the problem can be solved without the detour via step densities. This approach is not transferable to the case of loss minimization.

¹⁰Clearly, $U(x)$ and $V(x)$ coincide for a uniform fitness distribution.

¹¹See Robson (2001a, p. 16) for evolutionary arguments why preferences over consumption are likely to dominate preferences defined on reproductive value.

fitness through a function $\psi : Y \rightarrow [a, b]$. This again induces a distribution of fitness levels in X , for which an optimal utility function can be derived as above. The utility assigned to alternative $y \in Y$ then becomes $U(\psi(y))$, which will simply be denoted by $U(y)$ (or $V(y)$, respectively) with some abuse of notation.

For Theorem 2.1 to be applicable, the induced distribution of fitness levels needs to be representable by a bounded density $f(x)$ with finitely many discontinuities. This requirement is not very restrictive and can be ensured by various different joint assumptions on Y , ψ and G . For example, make the following (strong) assumption.

Assumption 2.1. $Y = [d, e]$, ψ is continuously differentiable with $\psi'(y) > 0$ for all $y \in Y$, $\psi(d) = a$ and $\psi(e) = b$, and the distribution on Y can be represented by a continuous density g .

Assumption 2.1 is by no means necessary for the theorem to be applicable, but it ensures that the induced fitness density $f(x)$ is continuous, producing continuously differentiable utility functions. These functions, defined on Y , are

$$U(y) = c \int_a^{\psi(y)} f(x)^{2/3} dx$$

for the expected loss criterion and

$$V(y) = F(\psi(y)) = G(y)$$

for the probability of mistakes criterion. Closer inspection of $U(y)$ reveals the following result:

Proposition 2.2. *Under Assumption 2.1, the function $U(y)$ is continuously differentiable with*

$$U'(y) = c g(y)^{2/3} \psi'(y)^{1/3}.$$

Proof. Derive the induced fitness distribution function $F(x)$ first. Since ψ is strictly increasing, $F(x) = G(\psi^{-1}(x))$ holds. Therefore, $F(x)$ is continuously differentiable under Assumption 2.1, with derivative $F'(x) = f(x) = g(\psi^{-1}(x))(\partial\psi^{-1}(x)/\partial x) = g(\psi^{-1}(x))/\psi'(\psi^{-1}(x))$. Hence

$$U'(y) = c \psi'(y) f(\psi(y))^{2/3} = c g(y)^{2/3} \psi'(y)^{1/3}.$$

□

The proposition shows that the slope of $U(y)$ at y corresponds to a normalized weighted geometric mean of the slope of the distribution function $G(y)$ and of the slope of the fitness function $\psi(y)$. The utility function $U(y)$ therefore represents an intermediate case between the actual fitness function $\psi(y)$ (properly normalized) and the distribution function $G(y)$. Intuitively, utility should again be steep in regions of Y where decisions have to be made often. However, since the size of mistakes – measured in fitness – matters as well, utility should also inherit properties of the fitness function ψ . Specifically, when ψ is steep somewhere, thresholds should be spaced closely there, because a wrong decision is severely damaging even if the two alternatives at choice are very close to each other. On the other hand, mistakes are not very damaging in regions where ψ is almost flat and all alternatives yield very similar fitness levels.

$U(y)$ is twice differentiable at each $y \in Y$ where $g(y)$ and $\psi'(y)$ are differentiable and $g(y) > 0$, with

$$U''(y) = \frac{2}{3}c \left(\frac{\psi'(y)}{g(y)} \right)^{1/3} g'(y) + \frac{1}{3}c \left(\frac{g(y)}{\psi'(y)} \right)^{2/3} \psi''(y).$$

The second derivative of $U(y)$ therefore corresponds to a weighted average (with varying weights) between the second derivatives of G and ψ . If, for example, the fitness function ψ is concave, utility can still be convex if G is convex.

So far, the assumption of a one-dimensional set of alternatives $Y \subseteq \mathbb{R}$ has been made. The model can be extended to higher-dimensional sets $Y \subseteq \mathbb{R}^n$, though, as long as there is a single-valued fitness function $\psi : Y \rightarrow [a, b]$ and a distribution function G on Y that induce a bounded fitness density $f(x)$ with finitely many discontinuities.¹² As above, the optimal utility from an alternative $y = (y_1, \dots, y_n) \in Y$ becomes

$$U(y_1, \dots, y_n) = c \int_a^{\psi(y_1, \dots, y_n)} f(x)^{2/3} dx.$$

Clearly, the resulting indifference curves coincide with fitness isoquants. Un-

¹²The combination of a multi-dimensional set of alternatives and a single-valued fitness function is referred to as a “fitness landscape” in biology (Wright 1932).

der the respective differentiability conditions,

$$\frac{\partial U(y)}{\partial y_i} = c \frac{\partial \psi(y)}{\partial y_i} f(\psi(y))^{2/3}$$

holds for all $i = 1, \dots, n$. Marginal utility is jointly determined by the density at bundle y 's induced fitness level, $f(\psi(y))$, and by the partial derivative of the fitness function, $\partial \psi(y)/\partial y_i$. Thus, it again reflects the importance of bundle y and specifically of its i 'th component in decisions.¹³

2.4 Hedonic Adaption

A choice situation as described above consists of a set of alternatives Y , a fitness function ψ , and a distribution function G . For this situation (Y, ψ, G) , an optimal utility function $U : Y \rightarrow [0, 1]$ can be obtained. If the decision situations that our ancestors faced varied systematically during a human lifetime, evolution will have selected individuals whose utility functions accommodate to change. Hence an *adaption mechanism* can be thought of as a family of utility functions together with a rule, which specifies what function becomes active at what point in time.

Consider first the case of a changing environment modeled through a changing distribution function as discussed in Section 2.1. In general, adaption of utility will have to be triggered by perceivable changes in the environment, which were (and might still be) correlated with changes in G , which is itself not directly observable. For example, an accumulation of large payoffs by oneself or others will generally indicate that the environment has developed in a favorable way, and hedonic adaption will occur.¹⁴ Realized payoffs are, however, not the only possible trigger. If, for example, the nature of decision problems changed systematically with individual age, utility should be expected to differ between age groups. Hedonic adaption to changes in G will mostly be discussed in the application in Section 4.

Apparently, choice situations can also differ with respect to the set of available alternatives Y . Hunter-gatherers are frequently confronted with typical hunt decisions, involving the choice between different hunting strate-

¹³Second partial derivatives can also be examined. The local curvature properties of U are again influenced by those of the fitness function and of the distribution function.

¹⁴This is essentially the adaption mechanism at work in Rayo and Becker (2007a) and (2007b), where realized payoffs contain information about the state of nature.

gies (which animal to hunt, which technique to use). The choice between different foraging strategies appears as a different decision problem, which can clearly be distinguished from the first one. Yet another choice situation will have involved the long-run choice between different areas of habitation. If individuals can distinguish these situations, evolution should have endowed them with context specific utility functions, each one tailored to a particular decision problem, and activated by the recognition of the respective choice situation. Within each of these context specific choice mechanisms, hedonic adaption to the environment occurs as described above. Section 3 contains an application of this idea to intertemporal decision-making.

2.5 Discussion

Kahneman, Wakker, and Sarin (1997) (KWS) distinguish two notions of hedonic utility: “instant utility” is the pain or pleasure that an individual experiences during a temporally extended outcome, while “remembered utility” refers to the individual’s retrospective hedonic evaluation of the experience.¹⁵ They show that the latter is an accurate predictor of behavior: after individuals have first been exposed to different treatments and have learned about their implications, they choose to repeat the treatment for which they report the largest level of remembered utility. Surprisingly, this level differs systematically from reports on instant utility during the initial treatments, indicating substantial flaws in memory. The model at hand might help to shed light on this puzzle. It will be argued that instant and remembered utility perform different tasks and have thus been shaped by different evolutionary forces.

Assume that an agent finds itself in an entirely new decision environment (Y, ψ, G) . For example, unfamiliar plants become available at a new location, and the consequences of consuming them are still unknown. It thus takes an initial phase of experimentation during which the new alternatives are explored. Formally, the agent collects information (not necessarily consciously) about fitness relevant characteristics of the new options and hence about the function ψ .¹⁶ This information subsequently finds its way into an optimally

¹⁵Temporally extended outcomes are treatments that last up to several minutes. KWS report on several studies where individuals were exposed to short films, medical treatments, and varying temperatures.

¹⁶Note that actual fitness implications need not be observable. Through consumption,

adapted hedonic utility function. By construction, this utility function determines decisions, and thus corresponds to what KWS call remembered utility. If an individual is asked to assess alternatives during later choice situations, it “remembers” their fitness relevant characteristics and evaluates them accordingly. From this perspective, the expression “remembered utility” might be misleading, as optimal decision-makers will remember fitness relevant characteristics and report a current evaluation of them, rather than a recollection of previous hedonic experience.

This interpretation offers a first idea as to the evolutionary role of instant utility. Any initial phase of experimentation must involve substantial dangers due to the novelty of alternatives. It is then clearly expedient to have a warning system that keeps track of all relevant information during the consumption of temporally extended outcomes. The main purpose of instant utility might thus be to give “a ‘stop’ signal” (KWS, p. 379) early enough to prevent enduring damage to the individual. Naturally, this warning system should only account for acute dangers and will not be able to judge overall fitness adequately. Therefore, instant and remembered utility will only be vaguely correlated, and it is no flaw if individuals do not remember past hedonic experiences correctly. Reports or physiological measurements of hedonic values will only provide suitable predictions for behavior if they are elicited in a framing that resembles an actual choice situation.

3 Intertemporal Preferences

3.1 A Discrete Time Model

To apply the results of Section 2 to intertemporal preferences, the following model allows alternatives to differ both in payoff $v \in [0, 1]$ and in waiting time $t \in \{0, 1, \dots, T\}$, after which the payoff is realized. Assume that the fitness of an alternative $y = (t, v)$, evaluated at the point in time where the choice is made, is given by the exponential function $\psi(t, v) = \delta^t v$, where $0 < \delta < 1$ is a discount factor. There are various reasons for discounting delayed payoffs in such a way. If, for example, there is a constant hazard that the payoff vanishes while the agent waits for it, as in Sozou (1998) or Dasgupta and Maskin (2005), the expected fitness of an alternative can be

the agent will rather learn about characteristics such as nutritiousness or health impacts.

expressed as above. Alternatively, population growth (Hansson and Stuart 1999, Robson and Samuelson 2007) or declining fertility (Rogers 1994) can be reasons for exponential fitness discounting.

Alternatives are drawn as follows. First, a waiting time is drawn according to strictly positive probabilities $p_t, t = 0, \dots, T$. Conditional on t , a payoff v is then chosen according to a distribution function $G_t(v)$ with continuous density $g_t(v)$. Issues related to returns on investment can be captured by the assumption that the densities g_t vary with t in a systematic way. This setup will be referred to as the discrete time model in the following. Lemma 3.1, proven in the Appendix, characterizes the induced fitness distribution.

Lemma 3.1. *In the discrete time model, fitness levels are distributed in $X = [0, 1]$ according to the density*

$$f(x) = \sum_{t=0}^{\hat{t}(x)} \frac{p_t}{\delta^t} g_t\left(\frac{x}{\delta^t}\right),$$

where $\hat{t}(x)$ is the largest waiting time t for which $x \leq \delta^t$ holds.

Observe that the fitness density $f(x)$ is left-continuous with possible downwards jumps at the points $x = \delta^t$ for $t = 1, \dots, T$. A jump occurs because slightly larger fitness levels than x are no longer attainable with a waiting time of $\hat{t}(x)$ if $x = \delta^t$, i.e. $\hat{t}(x)$ is a step function with downwards jumps at $x = \delta^t, t = 1, \dots, T$. The following sections will repeatedly make use of different versions of the discrete time model.

3.2 Multiple Selves

The idea of context specific utility functions as an optimal solution in the presence of separable decision situations has been introduced in Section 2.4. Consider then a modified version of the discrete time model, where the agent is faced with two possible choice situations. The first one involves short-run alternatives with waiting time $t = 0$ and payoffs v that are drawn from $[0, 1]$ according to the density g_0 . The second situation involves alternatives with waiting times $t \in \{1, 2\}$, where $t = 1$ occurs with probability $0 < p < 1$ and $t = 2$ occurs with probability $1 - p$. Payoffs are drawn from $[0, 1]$ conditional on waiting time according to the densities g_1 and g_2 . The type of decision situation (short-run vs. long-run) is revealed to the agent before the actual

choice, so that an optimal utility function can be activated. Hence a function $U(0, v)$ evolves independently from $U(t, v)$ for $t = 1, 2$. These two functions, or decision mechanisms, can be interpreted as the “multiple selves” proposed by Winston (1980), Schelling (1984) and Ainslie and Haslam (1992).¹⁷ In a recent study, McClure, Laibson, Loewenstein, and Cohen (2004) find that there are actually two different neural systems involved in intertemporal decision-making. Functional magnetic resonance imaging reveals that the limbic system is especially active when immediate payoffs are evaluated, while the lateral prefrontal cortex is relatively more engaged in long-run decisions.

The model thus offers an evolutionary rationale for the existence of multiple selves and explains “why either type of agent emerges when it does” (Frederick, Loewenstein, and O’Donoghue 2002, p. 376). The crucial assumption behind the result is that the individual *either* faces two short-run *or* two long-run alternatives. In the first place, this captures the intuition that most decisions are between similar options, rather than between arbitrary alternatives, projects, or bundles of goods. More importantly, it involves the implicit assumption that choices are irreversible. An initial choice between two alternatives $(1, v_1)$ and $(2, v_2)$ appears as a choice between $(0, v_1)$ and $(1, v_2)$ one period later. If the initial choice could be reconsidered, short- and long-run decisions would no longer be separate. Irreversibility appears as a realistic assumption for many day-to-day decisions in hunter-gatherer societies. In particular, most of the examples that economists refer to in the discussion of preference reversals rely on the existence of money, credit and bank accounts, such as the premature spending of savings (Strotz 1955) or the effect of credit cards on savings (Laibson 1999). On the other hand, “all illiquid assets provide a form of commitment” (Laibson 1999, p. 444), and storage is necessarily illiquid in hunter-gatherer societies.¹⁸ Irreversibility of decisions will be assumed for the rest of this subsection, but the assumption will be dispensed with in Section 3.3.

The fitness of short-run alternatives is distributed in $[0, 1]$ according to the density $f_S(x) = g_0(x)$. In long-run decisions, fitness levels are distributed

¹⁷See also Thaler and Shefrin (1981), Elster (1985), Read (2001) and Fudenberg and Levine (2006).

¹⁸For example, storage in primitive societies takes the form of somatic capital or intergenerational transfers (Robson and Kaplan 2007), which makes any savings decision irreversible.

in $[0, \delta]$ according to

$$f_L(x) = \begin{cases} (p/\delta) g_1(x/\delta) & \text{if } x > \delta^2 \\ (p/\delta) g_1(x/\delta) + ((1-p)/\delta^2) g_2(x/\delta^2) & \text{if } x \leq \delta^2. \end{cases}$$

The utility function used to evaluate short-run alternatives is thus given by $U(0, v) = c_S \int_0^v f_S(x)^{2/3} dx$, while $U(t, v) = c_L \int_0^{\delta^t v} f_L(x)^{2/3} dx$ obtains for $t = 1, 2$. Now consider two long-run alternatives:

Definition 3.2. *The decision between $y_1 = (1, v_1)$ and $y_2 = (2, v_2)$ creates regret if (i) $U(1, v_1) \leq U(2, v_2)$, and (ii) $U(0, v_1) > U(1, v_2)$.*

Regret refers to a case in which the agent initially prefers the alternative with the larger waiting time, but, after one period has passed and the earlier alternative has moved to the presence, would prefer to reverse the decision. The main proposition in this section states that regret will arise whenever the agent is accustomed to sufficiently small payoffs in the short run. To be able to formalize “sufficiently small”, it makes use of the following definition.

Definition 3.3. *Let $h(v; \lambda)$ be a family of continuous densities on $[0, 1]$, parameterized by $\lambda > 0$, that satisfies for all $y > 0$*

$$\lim_{\lambda \rightarrow \infty} \frac{\int_0^y h(v; \lambda)^{2/3} dv}{\int_0^1 h(v; \lambda)^{2/3} dv} = 1.$$

According to the definition, raising λ shifts probability mass to the left, in the sense that the whole relative area under the function $h(v; \lambda)^{2/3}$ eventually concentrates below y as $\lambda \rightarrow \infty$, for any strictly positive y . This property is satisfied by several common distributions, such as the truncated exponential or a triangular distribution.¹⁹ It is now possible to state the following result, which is proven in the Appendix:

Proposition 3.4. *Assume that $g_1(v) > 0$ for all $v \in [0, 1]$. Then for any $v_1, v_2 \in (0, 1)$ with $v_1 \leq \delta v_2$, there exists a value $\bar{\lambda}(v_1, v_2) \in \mathbb{R}$ such that the decision between $y_1 = (1, v_1)$ and $y_2 = (2, v_2)$ creates regret if $g_0(v) = h(v; \lambda)$ for any $\lambda > \bar{\lambda}(v_1, v_2)$.*

¹⁹For the truncated exponential distribution with $h(v; \lambda) = (\lambda e^{-\lambda v})/(1 - e^{-\lambda})$, it follows that $(\int_0^y h(v; \lambda)^{2/3} dv)/(\int_0^1 h(v; \lambda)^{2/3} dv) = (1 - e^{-\frac{2}{3}\lambda y})/(1 - e^{-\frac{2}{3}\lambda})$, which satisfies Definition 3.3. It is straightforward to check the analogous property for a triangular distribution with $h(v; \lambda) = 2(\lambda + 1) - 2(\lambda + 1)^2 v$ if $v \leq 1/(\lambda + 1)$ and $h(v; \lambda) = 0$ otherwise.

If the agent is mostly confronted with small payoffs in short-run decisions, it will experience large levels of pleasure $U(0, v)$ even if v is small. This is a direct implication of the general insights derived in Section 2. Conflict between the farsighted and the myopic self is then more likely to occur. While the individual preferred the alternative with longer waiting time in the original decision, the earlier alternative becomes exceptionally tempting as soon as it has moved to the presence and is evaluated according to short-run utility.²⁰ Immediate payoffs will indeed tend to be smaller than delayed payoffs, during our ancestors' times as well as today, due to natural growth, interest, or because more important decisions are generally taken well in advance. These are the basic conditions that favor regret.

3.3 Dynamic Inconsistency and Precommitment

Regret as considered so far is of purely seductive nature. The agent would like to reverse the initial decision, but is not able to do so by assumption. As argued before, however, irreversibility of decisions is a much less plausible assumption for today's world than for the environment of our ancestors. If the modern individual is given the chance to reconsider its choice, regret will translate into a decision reversal. Dynamically inconsistent behavior is the result of maladaptation to a world in which decisions have become increasingly reversible.

Dasgupta and Maskin (2005) argue that reversals are the consequence of adaptation to a world in which the relative fitness of two alternatives actually changed as time went by.²¹ The advantage of the present approach is that it sheds light on the often observed awareness of future inconsistent behavior and the farsighted self's urge to constrain the myopic self.²² Successful precommitment makes long-run decisions irreversible and thus preserves the advantage of maintaining specialized decision mechanisms. One should therefore expect some degree of "sophistication" (Strotz 1955) to co-evolve with multiple selves. The coexistence of potentially conflicting decision mecha-

²⁰The model therefore explains why temptation (Gul and Pesendorfer 2001) can arise.

²¹They assume that payoffs can always realize earlier than expected. If early realization does not occur, the later alternative becomes relatively less fit. Sozou (1998) also discusses the evolution of non-exponential discounting, but the model does not explain dynamic inconsistency as considered here.

²²Frederick, Loewenstein, and O'Donoghue (2002), for example, pose the question why "farsighted selves often attempt to control the behaviors of myopic selves, but never the reverse" (p. 376).

nisms and the ability to foresee future choice inconsistencies is then not at all paradoxical: context specific utility functions make better choices possible, and self-constraints prevent wrong utility functions from interfering later.

4 Attitudes Towards Risk

Some first implications for the curvature properties of optimal utility functions follow immediately. Assume again that individuals choose directly between fitness levels from $X = [a, b]$, which are drawn and offered according to a density $f(x)$. Under the assumption that f is differentiable, the Arrow-Pratt coefficients of absolute risk-aversion RA_U and RA_V for the two functions U and V can then easily be calculated:

Corollary 4.1. *If $f(x)$ is differentiable and $f(x) > 0$,*

$$RA_V(x) = -\frac{f'(x)}{f(x)} \quad \text{and} \quad RA_U(x) = -\frac{2}{3} \frac{f'(x)}{f(x)}.$$

Both $U(x)$ and $V(x)$ will be locally concave (convex) where $f(x)$ is strictly decreasing (increasing). This corresponds to areas where choices involve alternatives with small payoffs more (less) often than alternatives with large payoffs. Assume, for example, that $X = [0, b]$, $b > 0$, and alternatives are drawn from X according to a truncated exponential distribution with rate parameter $\lambda > 0$, so that $f(x) = (\lambda e^{-\lambda x}) / (1 - e^{-\lambda b})$ is strictly decreasing in x . The parameter λ measures how frequently choices involve small fitness levels. As λ grows, probability mass is shifted towards smaller alternatives. It now follows that $RA_V = \lambda$ and $RA_U = \frac{2}{3}\lambda$, i.e. both $U(x)$ and $V(x)$ exhibit constant absolute risk-aversion. Risk-aversion is, however, still decreasing in the sense that a decrease in λ , which corresponds to a shift of probability mass to larger payoffs, reduces risk-aversion.

Assume now that $f(x)$ is single-peaked with peak in the interior of X . This appears as a sensible description of both hunter-gatherers' environment and today's decision situations, where most opportunities involve middle-sized rather than extremely small or large payoffs.

Corollary 4.2. *If f is continuous and single-peaked with peak at $\hat{x} \in (a, b)$, then both $U(x)$ and $V(x)$ are S-shaped with inflection point \hat{x} .*

A utility function as described in the corollary resembles the value function used in prospect theory.²³ Two main insights derive from this analysis. First, it delivers an evolutionary foundation for the “principle of diminishing sensitivity” to payoffs (Tversky and Kahneman 1992). It has been the main argumentation in Section 2 that an individual’s hedonic sensitivity will decline towards payoffs that are rarely encountered, and thus towards the extremes under reasonable assumptions.²⁴ Second, \hat{x} can be interpreted as the decision maker’s reference point. Decisions among alternatives close to \hat{x} are most likely, and the agent will be accustomed to this level. Hence even though the agent’s payoff fluctuates over time, the reference point does not adjust to any newly experienced payoff. It will remain fixed as long as the density $f(x)$ remains the same. Adjustments of the reference point should therefore not be expected in response to random payoff realizations, but only to systematic changes of the environment, which in turn might be indicated by an accumulation of previously uncommon payoffs.

An additional feature of prospect theory is loss aversion, the fact that losses relative to the reference point seem to have a larger impact on individuals than gains of the same size. This has inspired the conjecture that gains and losses are evaluated by separate neural mechanisms, a hypothesis which was not confirmed by the results of Tom, Fox, Trepel, and Poldrack (2007). Instead, they find a neural correlate of behavioral loss aversion in a single neural system, which in addition is known to be responsible for hedonic experiences.²⁵ Within this system, “the (negative) slope of the decrease in activity for increasing losses was greater than the slope of the increase in activity for increasing gains in a majority of participants” (p. 517).

The apparent existence of a single hedonic evaluation mechanism for gains and losses is in line with the approach in this section. Obtaining the necessary downward kink of the value function in the present framework requires a downward jump of the fitness density at its peak. What may appear as a rather ad hoc assumption arises naturally under reasonable circumstances. Reconsider the discrete time model from Section 3, with just two time periods

²³Rayo and Becker (2007a) show that their step function can become S-shaped if evolution cannot incorporate all relevant information into the happiness function.

²⁴As shown before, hedonic sensitivity is also influenced by the fitness function ψ . Concavity of ψ , for example, constitutes a reason for risk-aversion. Except if this effect is strong, utility will still be S-shaped under an S-shaped distribution function G .

²⁵This system includes parts of the prefrontal cortex and the striatum.

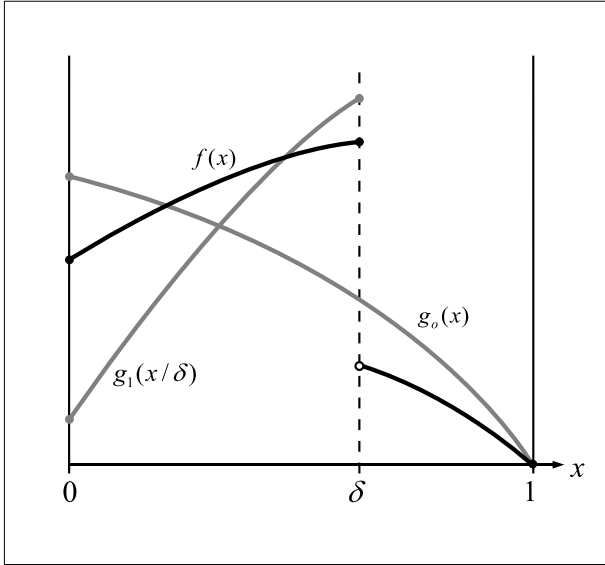

Figure 1: Single-peaked fitness density $f(x)$ (black) with downward jump at δ , based on short-run alternatives that induce the fitness density $g_0(x)$ and long-run alternatives that induce the fitness density $g_1(x/\delta)$ (both gray).

($T = 1$). To capture the idea that instantaneous payoffs are usually smaller than later payoffs, for example due to natural growth, assume that $g_0(v)$ is strictly decreasing while $g_1(v)$ is strictly increasing in v . It then immediately follows that the induced fitness density $f(x)$ is decreasing in x for $x > \delta$. If, in addition, $g_1(v)$ is increasing strongly enough, $f(x)$ will be increasing in x for $x \leq \delta$. The density $f(x)$ is then single-peaked with a downward jump at the peak $\hat{x} = \delta$ (see Figure 1), and $U(0, v)$ has a kink at its reference point. In addition to discounting, there are other interpretations of the model that should be pointed at. An alternative $(0, v)$ could represent a project with payoff v that an agent can carry out by itself, while the project $(1, v)$ requires the help of a collaborator who receives a share $1 - \delta$ of the payoff. Similar conclusions could be derived from other models in which alternatives differ with respect to a binary characteristic.

5 Conclusions

Under the assumption that human decisions are motivated by the pursuit of happiness, this paper derives optimal hedonic utility functions as situation-specific tools for evolutionary success. If utility can only be perceived in discrete shades, different utility functions are differently well adapted to a choice situation. Evolution will select a function which is steep in regions where decisions have to be made frequently and errors are especially harmful. If these characteristics differ between choice situations, hedonic utility will adapt. Application of this insight yields evolutionary explanations for well-documented patterns of risk attitudes and for time inconsistent preferences.

The general model of hedonic adaption reveals that the slope of utility can be interpreted as the degree of attention devoted to the respective area. The central result then confirms the intuition that maximal fitness can be attained by allocating attention according to cost-benefit considerations. This economic argument might provide explanations for several behavioral patterns that present anomalies for the standard economic approach, among them what has been described as “mental accounting” (Thaler 1999) or “choice bracketing” (Read, Loewenstein, and Rabin 1999). Both theories are related to the multiple selves approach to time discounting (Shefrin and Thaler 1988), and the present results might help to understand why different accounts or brackets exist and under which circumstances they become active.

6 Appendix

6.1 Approximation of f

Assume without loss of generality that f is left-continuous and consider a step density \hat{f}_S that approximates f as follows. Let $y_i, i = 1, \dots, D - 1$, be the points (in increasing order) where f is discontinuous, and define $y_0 := a$ and $y_D := b$, where $D \geq 1$. Hence X can be partitioned into D intervals on which f is continuous. Each of these intervals is then decomposed into $S \geq 1$ steps of equal length, so that there are $S \cdot D$ steps altogether. For $i = 1, \dots, SD - 1$, let $\pi(i) = \lfloor i/S \rfloor$ be the largest integer smaller or equal to

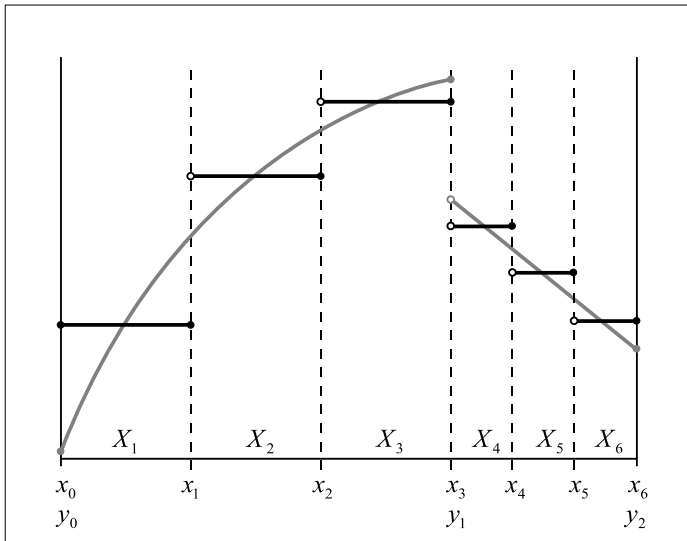

Figure 2: A left-continuous density f (gray) with one discontinuity ($D = 2$) is approximated by a left-continuous step density (black) with 6 steps ($S = 3$).

i/S . Then define $x_0 := a$, $x_{SD} := b$ and for each $i = 1, \dots, SD - 1$,

$$x_i := y_{\pi(i)} + (i - \pi(i) \cdot S) \left(\frac{y_{\pi(i)+1} - y_{\pi(i)}}{S} \right).$$

Now let $X_0 := \emptyset$ and for $i = 1, \dots, SD$ define $X_i := \{x \in X \mid x \leq x_i\} \setminus \bigcup_{j=0}^{i-1} X_j$. Clearly, f is continuous on each step X_i , $i = 1, \dots, SD$. Denote by $L(X_i) := x_i - x_{i-1}$ the length of step X_i . Now define

$$\hat{f}_S := \sum_{i=1}^{SD} \mathbb{I}_{X_i} f_i$$

where \mathbb{I}_{X_i} is the indicator function of X_i , and $f_i := (1/L(X_i)) \int_{x_{i-1}}^{x_i} f(y) dy$ is a value taken by $f(x)$ somewhere on X_i (by continuity of f on X_i), which makes sure that \hat{f}_S is again a density. Since f is continuous and bounded on each of the D intervals defined above, it also follows that \hat{f}_S converges uniformly to f as $S \rightarrow \infty$. The approximation is illustrated in Figure 2.

6.2 Proof of Theorem 2.1

Given a density f , the expected fitness loss due to wrong decisions can be written as follows. Assume a first alternative $x \in [t_k, t_{k+1}]$ has been drawn from between two neighboring thresholds (or a boundary, respectively) that are located at positions t_k and t_{k+1} , where $t_k \leq t_{k+1}$. Then

$$\mathcal{L}(x|t_k, t_{k+1}) = \int_{t_k}^{t_{k+1}} \frac{1}{2}|y - x|f(y)dy$$

is the expected loss conditional on x . The unconditional expected loss between t_k and t_{k+1} becomes

$$\mathcal{L}(t_k, t_{k+1}) = \int_{t_k}^{t_{k+1}} \mathcal{L}(x|t_k, t_{k+1})f(x)dx.$$

The overall loss of a threshold allocation is obtained by adding this expression for all intervals between thresholds (and the boundaries).

Now consider the step density \hat{f}_S as defined in section 2 and examine two neighboring thresholds at $t_k, t_{k+1} \in X_i$ for some $i \in \{1, \dots, SD\}$. It follows that

$$\mathcal{L}(t_k, t_{k+1}) = \frac{1}{6}(f_i)^2(t_{k+1} - t_k)^3.$$

Consider first the problem of optimal threshold positions under the constraint that exactly N_i thresholds are allocated to step $i = 1, \dots, SD$. Whenever $f_i = 0$ on some step i , $N_i = 0$ will clearly be optimal. All following arguments then apply unaltered by simply passing over this step. Hence for the moment assume $f_i > 0$ and $N_i \geq 1$ for all $i = 1, \dots, SD$. Whenever $N_i \geq 3$, all thresholds in X_i must clearly be equidistant. This follows from observing that the distance between two thresholds enters the loss as a cubic term. Hence whenever $N_i \geq 2$, the thresholds span $N_i - 1$ intervals of length l_i in the interior of X_i , where the dependency of l_i on the whole profile N_1, \dots, N_{SD} is omitted for notational simplicity. There is one additional interval between a and the first threshold, and one additional interval between the last threshold and b . Furthermore, for each $i = 1, \dots, SD - 1$ there is one interval between the last threshold in X_i and the first threshold in X_{i+1} . A simple example is given in Figure 3(a).

Let $N_1(N), \dots, N_{SD}(N)$ describe the optimal number of thresholds on each step if N thresholds are available altogether, which satisfies $\sum_{i=1}^{SD} N_i(N) =$

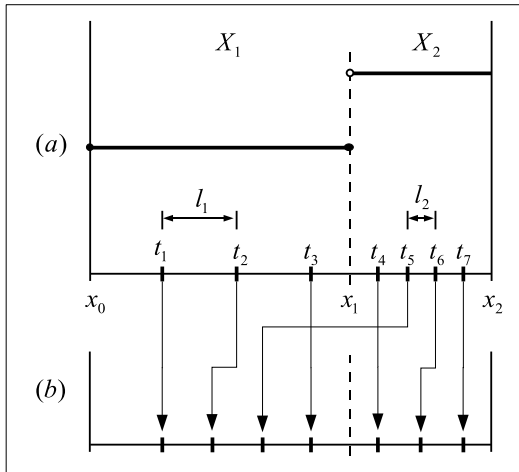

Figure 3: (a) Step density with 2 steps, $N = 7$, $N_1 = 3$, $N_2 = 4$. (b) A threshold is moved from step X_2 to step X_1 as described in the proof.

N .²⁶ As $N \rightarrow \infty$, clearly $N_i(N) \rightarrow \infty$ for at least one step i , which implies $\lim_{N \rightarrow \infty} l_i = 0$. Assume that one interior threshold is removed from X_i , while all other thresholds remain unchanged. This increases the loss by $\frac{1}{6}(f_i)^2(2l_i)^3 - \frac{2}{6}(f_i)^2(l_i)^3 = (f_i)^2(l_i)^3$, which goes to zero as $N \rightarrow \infty$. This implies that the distance between *any two* neighboring thresholds (or the boundaries a or b respectively) has to go to zero as $N \rightarrow \infty$. If it did not for two thresholds t_k and t_{k+1} , relocating an interior threshold from X_i to the interval (t_k, t_{k+1}) would eventually (for large enough N) decrease the overall loss. Hence, $N_i(N) \rightarrow \infty$ as $N \rightarrow \infty$ for all $i = 1, \dots, SD$. Furthermore, $\lim_{N \rightarrow \infty} (N_i(N) - 1)l_i = L(X_i)$.

Now consider a stronger necessary condition for optimality of $N_i(N)$, $i = 1, \dots, SD$, where N is assumed to be large enough to imply $N_i(N) \geq 3$ for all $i = 1, \dots, SD$. After taking one interior threshold out of step X_i , keep only the first and the last threshold in X_i fixed, and rearrange the remaining thresholds in between to make them equidistant again. This increases the loss by

$$\frac{1}{6}(f_i)^2(l_i)^3(N_i - 1)^3 \left[\frac{1}{(N_i - 2)^2} - \frac{1}{(N_i - 1)^2} \right].$$

²⁶The dependency of $N_i, i = 1, \dots, SD$, on N will sometimes be omitted for notational simplicity in the following.

Similarly, keep the first and last threshold in X_j , $j \neq i$, fixed, add the additional threshold in between, and rearrange to equidistant positions (as illustrated in Figure 3(b)). This decreases the loss by

$$\frac{1}{6}(f_j)^2(l_j)^3(N_j - 1)^3 \left[\frac{1}{(N_j - 1)^2} - \frac{1}{(N_j)^2} \right].$$

The condition for this not to decrease the overall loss can be rearranged to

$$\left(\frac{N_j}{N_i - 1} \right)^2 \left(\frac{N_j - 1}{N_i - 2} \right)^2 \left(\frac{2N_i - 3}{2N_j - 1} \right) \geq \left(\frac{f_j}{f_i} \right)^2 \left[\frac{(N_j - 1)l_j}{(N_i - 1)l_i} \right]^3. \quad (1)$$

If the same argument is repeated for the relocation of a threshold from step j to step i , one obtains

$$\left(\frac{N_j - 1}{N_i} \right)^2 \left(\frac{N_j - 2}{N_i - 1} \right)^2 \left(\frac{2N_i - 1}{2N_j - 3} \right) \leq \left(\frac{f_j}{f_i} \right)^2 \left[\frac{(N_j - 1)l_j}{(N_i - 1)l_i} \right]^3. \quad (2)$$

As $N \rightarrow \infty$, the identical RHS of (1) and (2) converges to $(f_j/f_i)^2(L(X_j)/L(X_i))^3$ from the above considerations. Denote the LHS of (1) by $a_{ij}(N)$ and the LHS of (2) by $b_{ij}(N)$. Since $N_i, N_j \rightarrow \infty$ as $N \rightarrow \infty$, it follows that $\lim_{N \rightarrow \infty} (a_{ij}(N)/b_{ij}(N)) = 1$. It then follows by a straightforward argument that $\lim_{N \rightarrow \infty} a_{ij}(N) = \lim_{N \rightarrow \infty} b_{ij}(N) = (f_j/f_i)^2(L(X_j)/L(X_i))^3$ must hold, since otherwise either (1) or (2) would be violated for large N . Given existence of this limit, it also holds that $\lim_{N \rightarrow \infty} a_{ij}(N) = \lim_{N \rightarrow \infty} b_{ij}(N) = \lim_{N \rightarrow \infty} (N_j/N_i)^3$, so that the limit optimality condition becomes

$$\lim_{N \rightarrow \infty} \frac{N_j(N)}{N_i(N)} = \left(\frac{f_j}{f_i} \right)^{2/3} \left(\frac{L(X_j)}{L(X_i)} \right) \quad (3)$$

for all $i, j = 1, \dots, SD$, $i \neq j$.

By fixing i and adding (3) for all $j = 1, \dots, SD$, it follows that

$$\lim_{N \rightarrow \infty} \frac{N_i(N)}{N} = \frac{f_i^{2/3} L(X_i)}{\sum_{j=1}^{SD} f_j^{2/3} L(X_j)}$$

for all $i = 1, \dots, SD$. This condition now also applies to steps where $f_i = 0$.

Now examine $U_{N,S}(x) := \theta_{N,S}(x)/N$. Denote by $\sigma_S(x)$ the number of the

step on which x is located, i.e. $x \in X_{\sigma_S(x)}$. It now follows that

$$U_S(x) := \lim_{N \rightarrow \infty} \frac{\theta_{N,S}(x)}{N} = \frac{\sum_{i=1}^{\sigma_S(x)-1} f_i^{2/3} L(X_i) + \gamma(x, S) f_{\sigma_S(x)}^{2/3}}{\sum_{j=1}^{SD} f_j^{2/3} L(X_j)}$$

where $\gamma(x, S) = x - x_{\sigma_S(x)-1}$ is the distance between x and the lower end of the step on which it is located. Observe that $f_i^{2/3}$ is a value taken by the function $f(x)^{2/3}$ somewhere on X_i , because f_i is taken by $f(x)$ somewhere on X_i . Furthermore, $f(x)^{2/3}$ is Riemann-integrable since it is bounded and has finitely many discontinuities on $[a, b]$. We thus obtain

$$U(x) := \lim_{S \rightarrow \infty} U_S(x) = c \int_a^x f(y)^{2/3} dy,$$

where $c = (\int_a^b f(y)^{2/3} dy)^{-1}$ is a normalizing constant.

The result on $V(x)$ stated in Theorem 2.1 follows easily by repeating all previous steps for the probability of mistakes, where the probability of a mistake between two thresholds $t_k, t_{k+1} \in X_i$ is $\mathcal{P}(t_k, t_{k+1}) = \frac{1}{2}(f_i)^2(t_{k+1} - t_k)^2$, analogously to $\mathcal{L}(t_k, t_{k+1})$ above. Hence for this case, the technique used here yields the same result that Robson (2001a) obtained.

6.3 Proofs for Section 3

Proof of Lemma 3.1. Conditional on having drawn $t \in \{0, 1, \dots, T\}$, the fitness levels are distributed in $[0, \delta^t]$ according to the distribution function $F_t(x) = G_t(x/\delta^t)$. Unconditionally, fitness levels are thus distributed in $[0, 1]$ according to the distribution function

$$F(x) = \sum_{t=0}^{\hat{t}(x)} p_t G_t\left(\frac{x}{\delta^t}\right) + \sum_{t=\hat{t}(x)+1}^T p_t,$$

where $\hat{t}(x)$ is the largest waiting time t for which $x \leq \delta^t$ still holds. For waiting times larger than $\hat{t}(x)$, even the best attainable fitness level will be smaller than x . It then follows immediately that $F(x)$ is differentiable everywhere except (possibly) at the points $x = \delta^t$ for $t = 1, \dots, T$, with derivative $f(x)$ as given in the Lemma.

Proof of Proposition 3.4. The condition that $v_1 \leq \delta v_2$, or $\psi(1, v_1) \leq$

$\psi(2, v_2)$, implies that $U(1, v_1) \leq U(2, v_2)$, which is condition (i) in the definition of regret. The assumption that $g_1(v) > 0$ for all $v \in [0, 1]$ implies that $f_L(x) > 0$ for all $x \in [0, \delta]$. This in turn implies that $0 < U(1, v_2) < 1$, because $0 < v_2 < 1$. Optimal short-run utility is given by

$$U(0, y) = \frac{\int_0^y h(v; \lambda)^{2/3} dv}{\int_0^1 h(v; \lambda)^{2/3} dv}.$$

According to Definition 3.3, $\lim_{\lambda \rightarrow \infty} U(0, y) = 1$ for all $y > 0$. Therefore, there exists a $\bar{\lambda}(v_1, v_2)$ such that $U(0, v_1) > U(1, v_2)$ for all $\lambda > \bar{\lambda}(v_1, v_2)$, which is condition (ii) in the definition of regret.

References

- Ainslie, G., and N. Haslam, 1992, Hyperbolic discounting, in G. Loewenstein, and J. Elster, ed.: *Choice Over Time* (Russell Sage Foundation: New York).
- Bechara, A., H. Damasio, and A.R. Damasio, 2000, Emotion, decision making and the orbitofrontal cortex, *Cerebral Cortex* 10, 295–307.
- Bergstrom, T.C., 1997, Storage for good times and bad: Of rats and men, Mimeo.
- Cooper, S.C., and R.H. Kaplan, 1982, Adaptive “coin-flipping”: A decision-theoretic examination of natural selection for random individual variation, *Journal of Theoretical Biology* 94, 135–151.
- Curry, P.A., 2001, Decision making under uncertainty and the evolution of interdependent preferences, *Journal of Economic Theory* 98, 357–369.
- Damasio, A.R., 1994, *Descartes’ Error: Emotion, Reason, and the Human Brain* (Avon: New York).
- Dasgupta, P., and E. Maskin, 2005, Uncertainty and hyperbolic discounting, *American Economic Review* 95, 1290–1299.
- Elster, J., 1985, Weakness of will and the free-rider problem, *Economics and Philosophy* 1, 231–265.

- Frederick, S., and G. Loewenstein, 1999, Hedonic adaptation, in Diener E. Kahneman, D., and N. Schwarz, ed.: *Well-Being: The Foundations of Hedonic Psychology* . pp. 302–329 (Russell Sage Foundation: New York).
- , and T. O’Donoghue, 2002, Time discounting and time preference: A critical review, *Journal of Economic Literature* 40, 351–401.
- Fudenberg, D., and D.K. Levine, 2006, A dual-self model of impulse control, *American Economic Review* 96, 1449–1476.
- Gardner, E., and J.H. Martin, 2000, Coding of sensory information, in E.R. Kandel, J.H. Schwartz, and T.M. Jessell, ed.: *Principles of Neural Science* . pp. 411–429 (McGraw-Hill: New York) 4 edn.
- Gul, F., and W. Pesendorfer, 2001, Temptation and self-control, *Econometrica* 69, 1403–1435.
- Hansson, I., and C. Stuart, 1990, Malthusian selection of preferences, *American Economic Review* 80, 529–544.
- Kahneman, D., and A. Tversky, 1979, Prospect theory: An analysis of decision under risk, *Econometrica* 47, 263–291.
- Kahneman, D., P.P. Wakker, and R. Sarin, 1997, Back to bentham? explorations of experienced utility, *The Quarterly Journal of Economics* 112, 375–405.
- Kringelbach, M. L., 2005, The human orbitofrontal cortex: Linking reward to hedonic experience, *Nature Reviews Neuroscience* 6, 691–702.
- Kupfermann, I., E.R. Kandel, and S. Iversen, 2000, Motivational and addictive states, in E.R. Kandel, J.H. Schwartz, and T.M. Jessell, ed.: *Principles of Neural Science* . pp. 998–1013 (McGraw-Hill: New York) 4 edn.
- Laibson, D., 1999, Golden eggs and hyperbolic discounting, *Quarterly Journal of Economics* 112, 443–477.
- McClure, S.M., D.I. Laibson, G. Loewenstein, and J.D. Cohen, 2004, Separate neural systems value immediate and delayed monetary rewards, *Science* 306, 503–507.

- Padoa-Schioppa, C., and J. A. Assad, 2006, Neurons in the orbitofrontal cortex encode economic value, *Nature* 441, 223–226.
- Rayo, L., and G.S. Becker, 2007a, Evolutionary efficiency and happiness, *Journal of Political Economy* 115, 302–337.
- , 2007b, Habits, peers, and happiness: An evolutionary perspective, *American Economic Review, Papers and Proceedings* 97, 487–491.
- Read, D., 2001, Intrapersonal dilemmas, *Human Relations* 54, 1093–1117.
- , G. Loewenstein, and M. Rabin, 1999, Choice bracketing, *Journal of Risk and Uncertainty* 19, 171–197.
- Robson, A.J., 1996, A biological basis for expected and non-expected utility, *Journal of Economic Theory* 68, 397–424.
- , 2001a, The biological basis of economic behavior, *Journal of Economic Literature* 39, 11–33.
- , 2001b, Why would nature give individuals utility functions?, *Journal of Political Economy* 109, 900–914.
- , and H.S. Kaplan, 2007, Why we grow large and then grow old: Economics, biology and mortality, Mimeo.
- Robson, A.J., and L. Samuelson, 2007, The evolution of intertemporal preferences, *American Economic Review* 97, 496–500.
- Rogers, A.R., 1994, Evolution of time preference by natural selection, *American Economic Review* 84, 460–481.
- Samuelson, L., 2004, Information-based relative consumption effects, *Econometrica* 72, 93–118.
- Schelling, T., 1984, Self-command in practice, in policy, and in a theory of rational choice, *American Economic Review* 74, 1–11.
- Shefrin, H.M., and R.H. Thaler, 1988, The behavioral life-cycle hypothesis, *Economic Enquiry* 26, 609–643.
- Sozou, P.D., 1998, On hyperbolic discounting and uncertain hazard rates, *Proceedings of the Royal Society of London Series B* 265, 2015–2020.

- Strotz, R.H., 1955, Myopia and inconsistency in dynamic utility maximization, *Review of Economic Studies* 23, 165–180.
- Thaler, R.H., 1999, Mental accounting matters, *Journal of Behavioral Decision Making* 12, 183–206.
- , and H.M. Shefrin, 1981, An economic theory of self-control, *Journal of Political Economy* 89, 392–406.
- Tom, S.M., C.R. Fox, C. Trepel, and R.A. Poldrack, 2007, The neural basis of loss aversion in decision-making under risk, *Science* 315, 515–518.
- Tversky, A., and D. Kahneman, 1992, Advances in prospect theory: Cumulative representation of uncertainty, *Journal of Risk and Uncertainty* 5, 297–323.
- Winston, G.C., 1980, Addiction and backsliding: A theory of compulsive consumption, *Journal of Economic Behavior and Organization* 1, 295–324.
- Wright, S., 1932, The roles of mutation, inbreeding, crossbreeding and selection in evolution, *Proceedings of the VI International Congress of Genetics* 1, 356–366.

THURGAU INSTITUTE
OF ECONOMICS
at the University of Konstanz

Hauptstr. 90
CH-8280 Kreuzlingen 2

Telefon: +41 (0)71 677 05 10
Telefax: +41 (0)71 677 05 11

info@twi-kreuzlingen.ch
www.twi-kreuzlingen.ch